

S 1/2 SE 1/4 SEC. 15 T1S, R3W
 POR. SEC. 22 T1S, R3W

1

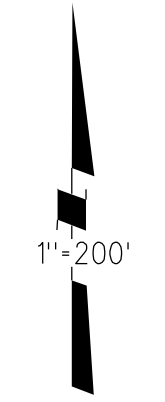

PB
271

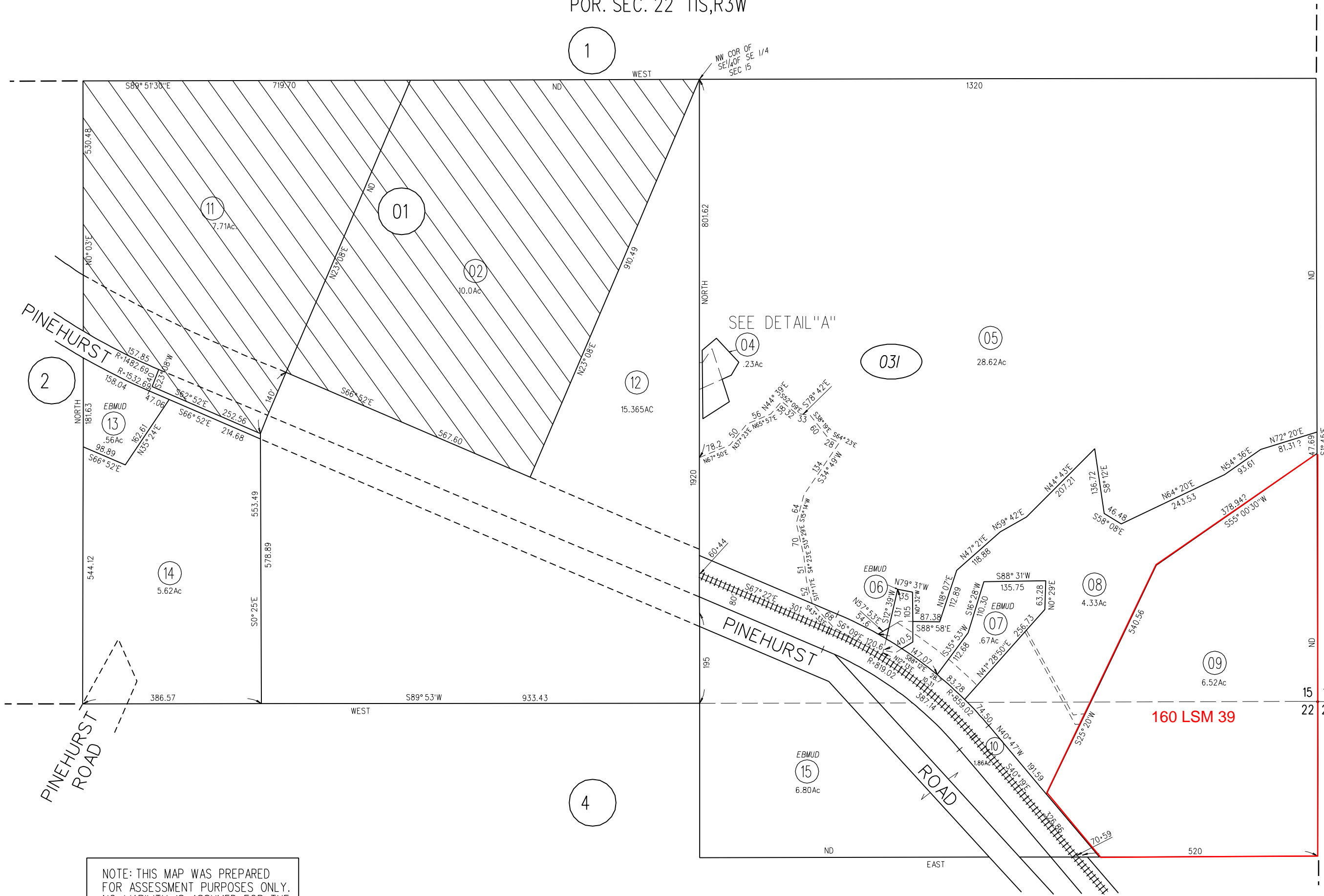
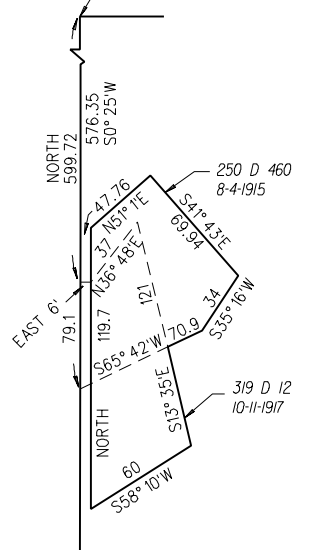

DETAIL "A"
SCALE - 1"=100'

NOTE: THIS MAP WAS PREPARED FOR ASSESSMENT PURPOSES ONLY. NO LIABILITY IS ASSUMED FOR THE ACCURACY OF THE INFORMATION DELINEATED HEREON.

8
031
032