

1996 ROLL-TRACT 7932 M.B. 382-10 (SKYLINE CONDOMINIUMS)  
 CONDO PLANS 96 4843 01-11-96  
 C.C.&R.'S 96 4844 01-11-96

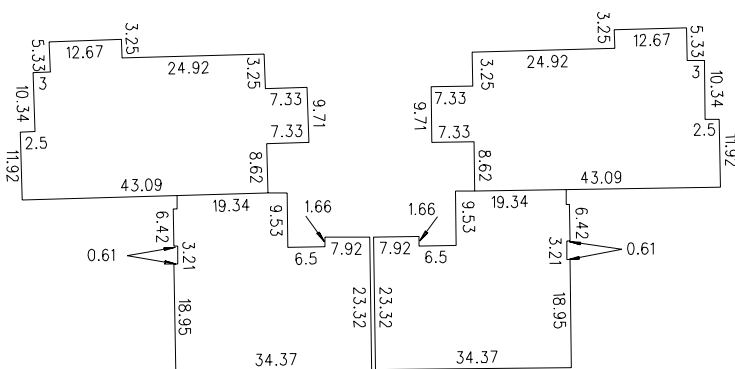

BUILDING "A" TYPE (TYPICAL)  
 NOT TO SCALE

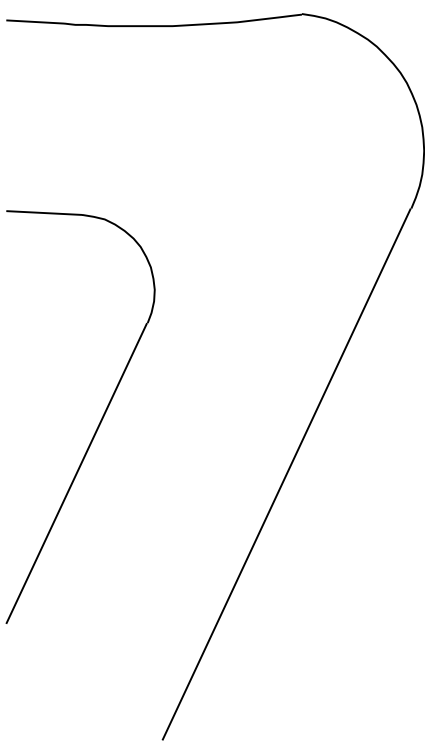
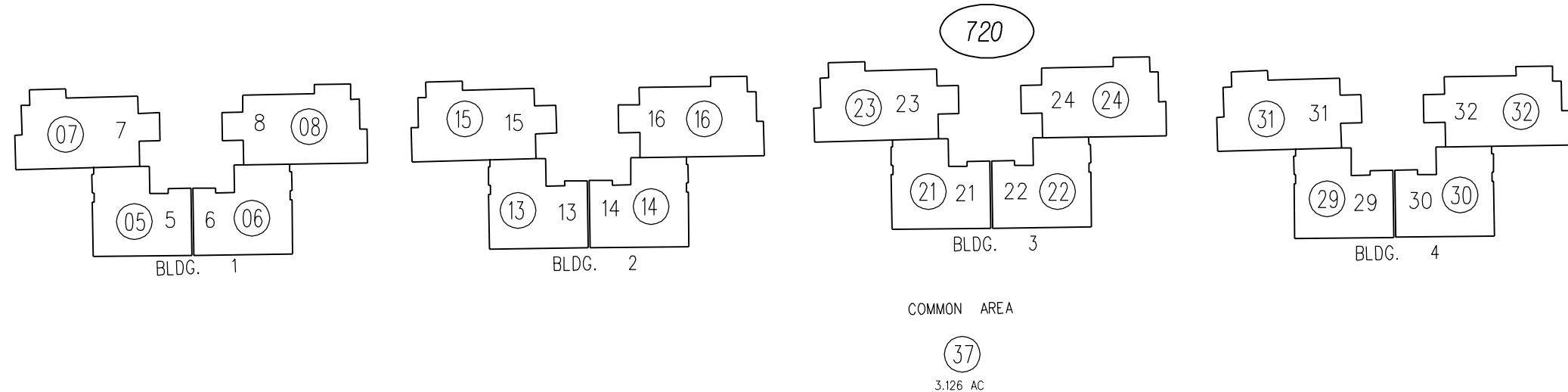
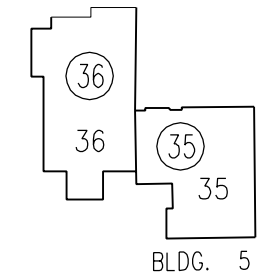
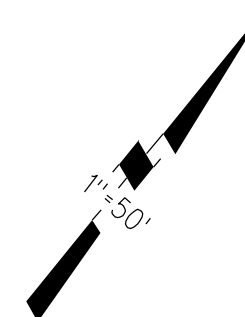

NOTE: THIS MAP WAS PREPARED FOR ASSESSMENT PURPOSES ONLY. NO LIABILITY IS ASSUMED FOR THE ACCURACY OF THE INFORMATION DELINEATED HEREON.

SECOND LEVEL

SHEET 2 OF 2

REVISED	CHANGE	BY
07-10-96	VAC FM RD TO LT1	MJ

720

FM. PG.28 05-03-96  
 ASSESSOR'S MAP  
 BOOK 208 PAGE 72-2  
 CONTRA COSTA COUNTY, CALIF.