

TO BK. 93-30

LANCASTER

LANE

35

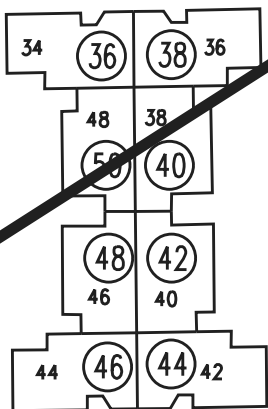
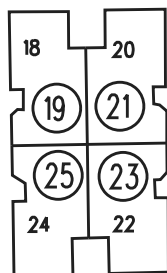
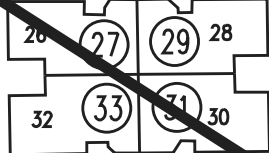
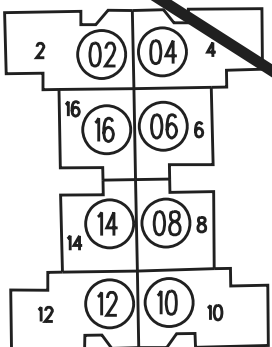

SECOND LEVEL

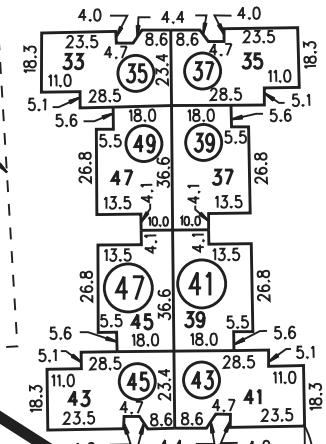
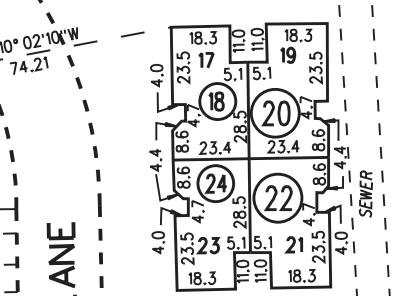
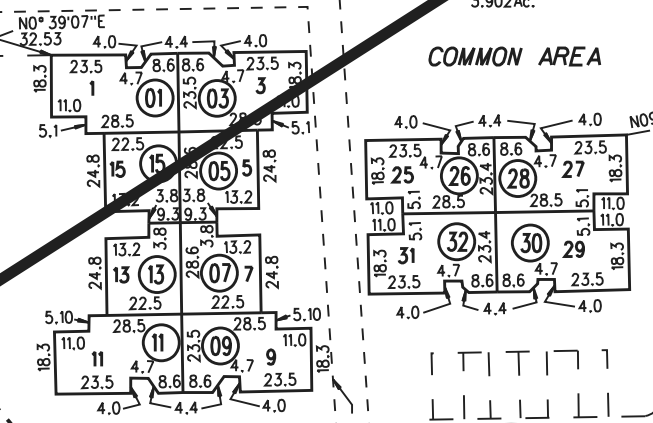

FIRST LEVEL

FALL RIVER DRIVE

DEVONSHIRE LANE

CHADWICK

CIRCLE

LANCASTER

36

440

26

440

45

33

440

44